



### IBSG

#### Intelligent 1G Bypass Switch

##### Product Description

Silicom Intelligent Bypass switch (IBSG) is an active external Bypass switch that protects network integrity from network failures and network maintenance. The Silicom intelligent Bypass switch (IBSG) generates the heartbeat and controls the mode of operation.

The Silicom Intelligent Bypass switch (IBSG) supports four modes of operations: Inline, Bypass, Tap and Linkdrop. In Inline mode, the IBS diverts inline network traffic to attached in-line network system. In Bypass mode, the IBS does not divert the traffic to the attached in-line network system and diverts it to other network link. In Tap mode, incoming traffic in port NET0 is mirrored to port MON0 and incoming traffic in port NET1 is mirrored to port MON1. In Linkdrop mode the IBS disables the links on the network ports (NET0, NET1). The IBS simulates switch / router cable disconnection.

The IBS generates the heartbeat packets and transmits the heartbeat packet to the in-line Monitor / Network appliance port, the Monitor Network appliance receives the heartbeat packets and transmits it to its other port (bridges the heartbeat packet). The IBS detects back the heartbeat packet and maintains the Inline mode.

The IBS sets to Bypass, Tap or Linkdrop when it does not receive back the heartbeat packet from the Network / Monitor appliance. When the Network / Monitor appliance recovers, it transmits back the heartbeat packet and the Intelligent switch sets to Inline. The IBS bypasses its Ethernet Monitor ports on event of power failure, Link failure, in-line software application system hang or user request.

The IBS includes Double Bypass Safe architecture. The Silicom Double Bypass safe architecture is based on two Bypass routing circuitry: An Active Bypass circuitry and Passive Bypass circuitry. If the internal active bypass routing circuitry fails, the passive Bypass routing circuitry is activated.



##### The IBS can be configured using:

- Simple CLI configuration management via a serial communication console port, Ethernet port using Telnet or SSH
- Web interface management interface
- SNMP

The IBSG includes two duplex LC ports for network ports, two 2 SFP ports for the attached in-line network system, serial port (RJ-11) and Ethernet port (RJ-45). The IBS supports Gigabit Multimode Fiber (1000Base-SX) and Gigabit single mode (1000Base-LX) network standards.

The IBS1U is a 1U host system supports up to four intelligent bypass switches (IBS). The Bypass Switch Host can support up to four intelligent Bypass Switch modules. The Bypass switch host includes two redundant 1 – 220 V AC power supply or two redundant -48 DC power supply.

**Figure: 1 – Front panel view of IBS**



**Figure: 2 – Front panel view of IBS with 4 modules**

## Key Features

- Self generating heartbeat pulses – No driver or management port is required to generate pulses
- Sets to Bypass when it detects in-line system failure
- Sets to Bypass when it detects in-line system link failure
- Sets to Bypass when it detects in-line software application system hang
- Sets to Bypass on Power failure
- Sets to Normal when it detects in-line system recovery
- Double Safe Bypass architecture with two routing circuitries
- Two on Board Watch Dog Timer (WDT) Controllers
- Software programmable time out interval
- Software Programmable WDT Enable / Disable
- Independent Bypass / Normal / Tap /Linkdrop operation in every module
- Supports up to four modules in a chassis
- Supports TAP mode of operation
- Simple CLI configuration management via serial port
- Telnet management interface via network management port
- SSH management interface via network management port
- Supports SNMP version 1, 2c, 3 (SHA, AES)
- Supports remote log
- Supports TACACS+
- Supports NTP
- Supports timezone
- Supports multi configuration backup
- Support Two ports link feature – if one of the network ports link fails it will drop the link on the other network port as well
- Two redundant power supplies
- Optional -48V DC power supplies

### IBS-SX

- Supports Short Range Fiber Gigabit Ethernet (1000Base-SX)

### IBS-LX

- Supports Short Range Fiber Gigabit Ethernet (1000Base-LX)

### IBSG-ZX

- Supports Long Range Fiber Gigabit Ethernet (1000Base-ZX)

## Technical Specifications

Bypass Specifications	
<b>WDT Interval (Software Programmable)</b>	Routing Transmit heart beat packet every 3mS – 10Sec. Default 5mS Verification packets received every 10mS – 50Sec. Default 20mSec Double Bypass Transmit heart beat packet every 300mS – 60Sec. Default 7Sec Verification packets received every 1S – 253Sec. Default 20Sec
Production Default configuration	
<b>Mode at Power up</b>	Bypass
<b>Heartbeat</b>	Activated
<b>Bypass Switch is ready and in-line device responds to heartbeat</b>	Change to Normal
<b>In-line device responds to heartbeat</b>	Normal
<b>In-line device does not respond heartbeat</b>	Bypass
<b>Mode at Power Off</b>	Bypass
<b>Heartbeat Packet</b>	Internetwork Packet Exchange
IBS1U: Bypass Switch 1U Host System	
<b>Dockings</b>	Front holders
<b>Voltage Input</b>	AC: 90-240 VAC Auto-Select -48 (-75 – -36) VDC

<b>Power Consumption</b>	160W maximum – When 4 IBS modules are installed
<b>Size</b>	444mm x 339.3mm x 44 mm ( 17.48" x 13.358" x 1.732") Wide x Depth X Height
<b>Operating Humidity</b>	0%–90%, non-condensing
<b>Operating Temperature</b>	0°C – 40°C (32°F – 104°F)
<b>Storage Temperature</b>	-20°C–65°C (-4°F–149°F)
<b>EMC Certifications</b>	Class B FCC / CE / VCCI
<b>MTBF*</b>	> 150,000 hours
<b>IBS1U: Bypass Switch 1U Host System LEDs / Connector Specifications</b>	
<b>LEDs:</b>	(2) Power LED – Green, Power is on, LED per power supply
<b>IBS -SX – Fiber Gigabit Ethernet Technical Specifications – (1000Base-SX) Adapters</b>	
<b>IEEE Standard / Network topology</b>	Fiber Gigabit Ethernet, 1000Base-SX (850nm)
<b>Data Transfer Rate</b>	2Gbit/s in full duplex mode per port
<b>Cables and Operating distance</b>	Multimode fiber:62.5um 137m maximum at 62.5 um ** Theoretical Distance – Defined as half a distance as stated by the IEEE 802.3 standard
<b>Output Transmit Power:</b>	Maximum:9.5dbm
<b>Output receive sensitivity:</b>	Minimum:-17dbm
<b>Insertion Loss ( Passive: Normal Mode)</b>	Typical: 0.8 dB Maximum: 1.9 dB
<b>Insertion Loss ( Passive: Normal Mode)</b>	Typical: 0.8 dB Maximum: 1.9 dB
<b>Voltage</b>	12V +/-5%
<b>Size</b>	173.3mm x 164.9mm x 20 mm ( 6.822" x 6.73" x 0.787") Wide x Depth X Height
<b>Operating Humidity</b>	0%–90%, non-condensing
<b>Operating Temperature</b>	0°C – 40°C (32°F – 104°F)

<b>Storage Temperature</b>	-20°C–65°C (-4°F–149°F)
<b>EMC Certifications</b>	Class B / FCC / CE / VCCI
<b>MTBF*</b>	> 150,000 hours

#### IBS-SX: LED and Connector Specifications

<b>LEDs:</b>	<p>Network / Monitor ports:  Link LED – (Green) On Link partner is detected.  Activity LED – (Yellow) Blinks on activity.  Power – Green power is on  Normal – Green, Switch in Normal mode.  SysOK – Yellow when Sys is OK,  WDT – Blink Yellow when WDT is activated  Light Yellow WDT time out  Off: WDT is disabled  Bypass – Red when bypass, off on Normal  Alarm – Red on system alarm</p>
<b>Connectors</b>	<p>Network: 2 LC Duplex  Monitor: 2 SFP  Management  RJ-11 serial port  RJ-45 Ethernet // optional for future use</p>

#### IBS-LX – Fiber Gigabit Ethernet Technical Specifications – (1000Base-LX) Adapters:

<b>IEEE Standard / Network topology</b>	Fiber Gigabit Ethernet, 1000Base-LX (1310nm)
<b>Data Transfer Rate</b>	2Gbit/s in full duplex mode per port
<b>Network ports Cables and Operating distance</b>	Single mode fiber: 5000m maximum at 9 um **
<b>Output Transmit Power:</b>	Maximum:11.5dbm
<b>Output receive sensitivity:</b>	Minimum:-19dbm
<b>Insertion Loss ( Passive: Normal Mode)</b>	Typical: 1.2 dB Maximum: 1.6dB
<b>Insertion Loss ( Passive: Bypass Mode)</b>	Typical: 1.2 dB Maximum: 1.6dB
<b>Voltage</b>	12V +/-5%
<b>Size</b>	173.3mm x 164.9mm x 20 mm ( 6.822" x 6.73" x 0.787")

<b>Operating Humidity</b>	0%–90%, non-condensing
<b>Operating Temperature</b>	0°C – 40°C (32°F – 104°F)
<b>Storage Temperature</b>	-20°C–65°C (-4°F–149°F)
<b>EMC Certifications</b>	Class B FCC / CE / VCCI
<b>Safety</b>	UL
<b>MTBF*</b>	> 150,000 hours

#### IBS-LX: LED and Connector Specifications

<b>LEDs</b>	<p>Network / Monitor ports:</p> <p>Link LED – (Green) On Link partner is detected.</p> <p>Activity LED – (Yellow) Blinks on activity.</p> <p>Power – Green power is on</p> <p>Normal – Green, Switch in Normal mode.</p> <p>SysOK – Yellow when Sys is OK,</p> <p>WDT – Blink Yellow when WDT is activated</p> <p>Light Yellow WDT time out</p> <p>Off: WDT is disabled</p> <p>Bypass – Red when bypass, off on Normal</p> <p>Alarm – Red on system alarm</p>
<b>Connectors</b>	<p>Network: 2 LC Duplex</p> <p>Monitor: 2 SFP</p> <p>Management</p> <p>RJ-11 serial port</p> <p>RJ-45 Ethernet // optional for future use</p>

#### Fiber Gigabit Ethernet Technical Specifications – (1000Base-ZX) Adapters:

<b>IEEE Standard / Network topology:</b>	Fiber Gigabit Ethernet, 1000Base-ZX (1550nm)
<b>Data Transfer Rate:</b>	2Gbit/s in full duplex mode per port
<b>Cables and Operating distance:</b>	<p>Single mode fiber:9/125um</p> <p>35Km maximum at 9 um **</p> <p>Theoretical Distance – Defined as half a distance as stated by the IEEE 802.3 standard</p>
<b>Voltage:</b>	12V +/-5%
<b>Size:</b>	<p>173.3mm x 164.9mm x 20 mm ( 6.822" x 6.73" x 0.787")</p> <p>Wide x Depth X Height</p>
<b>Operating Humidity:</b>	0%–90%, non-condensing

<b>Operating Temperature:</b>	0°C – 40°C (32°F – 104°F)
<b>Storage Temperature:</b>	-20°C–65°C (-4°F–149°F)
<b>EMC Certifications:</b>	Class B / FCC / CE / VCCI
<b>MTBF*:</b>	> 150,000 hours
<b>IBSG-ZX: LED and Connector Specifications</b>	
<b>LEDs:</b>	<p>Network / Monitor ports:  Link LED – (Green) On Link partner is detected.  Activity LED – (Yellow) Blinks on activity.  Power – Green power is on  Normal – Green, Switch in Normal mode.  SysOK – Yellow when Sys is OK,  WDT – Blink Yellow when WDT is activated  Light Yellow WDT time out  Off: WDT is disabled  Bypass – Red when bypass, off on Normal  Alarm – Red on system alarm</p>
<b>Connectors:</b>	<p>Network: 2 LC Duplex  Monitor: 2 SFP 1000BaseLX  Management  RJ-11 serial port  RJ-45 Ethernet // optional for future use</p>

**Description**

**Figure: 3 – Normal Mode Functional Block Diagram**

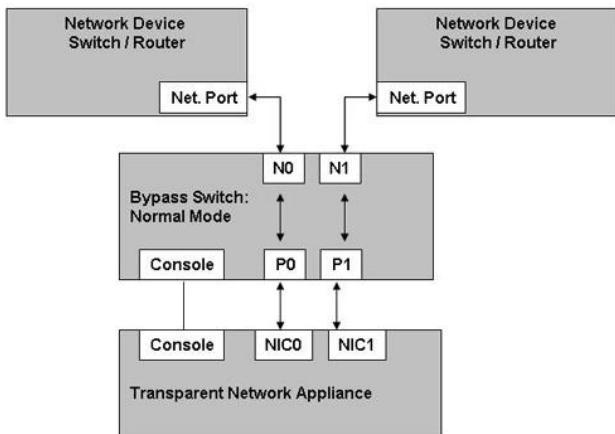

Figure: 4 – Bypass Mode Functional Block Diagram

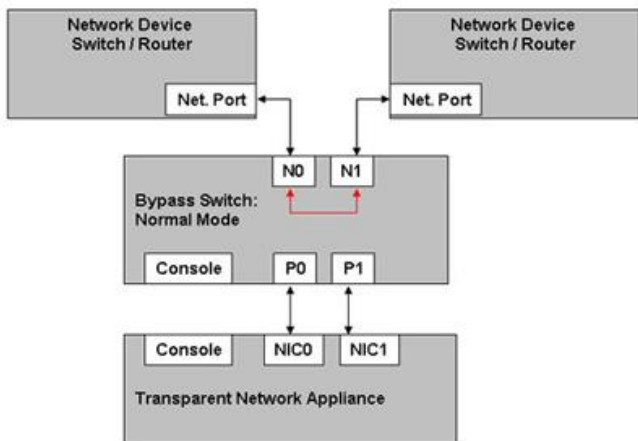

Figure: 5 – Tap Mode Functional Block Diagram

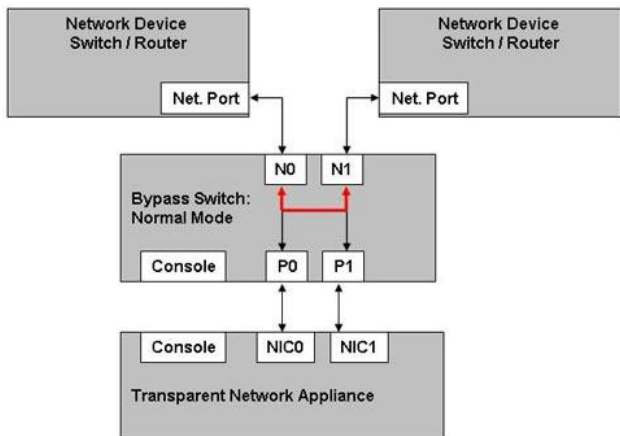
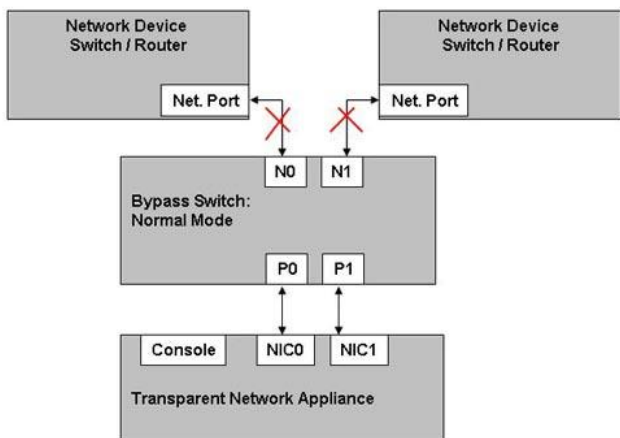

Figure: 6 – Linkdrop Mode Functional Block Diagram





## Order Information

IBS	System Format	Media	Media Type	Power Cord	-R
IBSGP: Intelligent Bypass Switch	1U: 1U	G: 1Gb	SX: Multimode LX: Single mode	-US -EU -CN -48	ROHS

P/N	Description	Notes
<b>IBSGP-SX</b>	Gigabit Fiber (SX) Intelligent Bypass Switch	Multimode, module only
<b>IBSGP-LX</b>	Gigabit Fiber (LX) Intelligent Bypass Switch	Singlemode, module only
<b>IBSGP-ZXLX</b>	Gigabit Fiber (ZX) Intelligent Bypass Switch	Singlemode, module only, ZX on the network ports, LX on the Monitor ports
<b>IBSSGP-SX-US</b>	Stand alone Gigabit Fiber (SX) Intelligent Bypass Switch	Multimode, stand alone, 110V cable
<b>IBSSGP-LX-EU</b>	Stand alone Gigabit Fiber (LX) Intelligent Bypass Switch	Single mode, stand alone, 220V cable
<b>IBSSGP-ZXLX-EU</b>	Stand alone Gigabit Fiber (ZX) Intelligent Bypass Switch	ZX on the network ports, LX on the Monitor ports , Single mode, stand alone, 220V cable
<b>RK-1U-2-IBSS</b>	1U Rack Mount Kit for two IBSS products	
<b>IBS1UP-US</b>	Intelligent Bypass Switch 1U host system	1U host system,(90-240 VAC Auto-Select), US cable
<b>IBS1UP-EU</b>	Intelligent Bypass Switch 1U host system	1U host system,(90-240 VAC Auto-Select), EU cable
<b>IBS1UP-CN</b>	Intelligent Bypass Switch 1U host system	1U host system,(90-240 VAC Auto-Select), CN cable
<b>IBS1UP-48</b>	Intelligent Bypass Switch 1U host system	1U host system,(-75 – -36) VDC
<b>IBSG1UP-1SX-EU</b>	1U w/ Gigabit Fiber (SX) Intelligent Bypass Switch	Multimode, 1U host, EU cable

<b>IBSG1UP-1LX-EU</b>	1U w/ Gigabit Fiber (LX) Intelligent Bypass Switch	Single mode, 1U host, EU cable
<b>IBSG1UP-1LX-48</b>	1U w/ Gigabit Fiber (LX) Intelligent Bypass Switch	Single mode, 1U host, -48V redundant power supply
<b>IBSG1UP-1ZXLX-US</b>	1U w/ Gigabit Fiber (ZX) Intelligent Bypass Switch	ZX on the network ports, LX on the Monitor ports, 1U host, US cable
<b>IBSG1UP-2SX-CN-R</b>	1U w/ Two Gigabit (SX) Intelligent Bypass Switch.	2 x Multimode, 1U host, CN cable
<b>IBSG1UP-2LX-48</b>	1U w/ Gigabit Fiber (LX) Intelligent Bypass Switch	2 x Single mode, 1U host, -48V redundant power supply
<b>IBSG1UP-1LX-1SX-EU</b>	1U w/ Two Gigabit Intelligent Bypass Switch. One (LX) and one (SX)	1 x Single mode, 1x Multimode, 1U host, EU cable

Note: Model P/N

-US: Includes US power cable (90-240 VAC Auto-Select)

-EU: Includes EU power cable (90-240 VAC Auto-Select)

-CN: Includes CN power cable (90-240 VAC Auto-Select)

-48: (-75 – -36) VDC

**2V3**