



M1E2G4BPi80

Quad Port Copper Gigabit Ethernet Express Module Bypass Server Adapter

Product Description

Silicom's Quad Port Copper Gigabit Ethernet ExpressModule Bypass server adapter is a PCI-Express X8 network interface card that contains four ports on a PCI-E adapter.

Silicom's Quad Port Gigabit Ethernet Bypass server adapter supports Normal and Bypass modes.

In Normal mode, the ports are independent interfaces. In Bypass mode, all packets received from one port are transmitted to adjacent port. In Disconnect mode, the adapter simulates switch / rout cable disconnection.

In Bypass mode, the connections of the Ethernet ports are disconnected from the system and switched over to the other port to create a crossed connection loop-back between the Ethernet ports.

Hence, in bypass mode all packets received from one port are transmitted to the adjacent port and vice versa. This feature enables to bypass a failed system and provides maximum up time for the network.

In Disconnect mode, the adapter simulates switch / router cable disconnection. In Disconnect mode, the switch / router does not detect link partner of the adapter.

Silicom's Quad Port Copper Gigabit Ethernet ExpressModule Bypass server adapters include an on board WDT (Watch Dog Timer) controller.

The adapter's software drivers or software application can write commands to the on board WDT controller. The adapter's software drivers, WDT controller and the Bypass circuitry provide an interface that control and manage the mode of the adapter.

Silicom's Quad Port Copper Gigabit Ethernet ExpressModule Bypass server adapters are based on Intel 82580EB Ethernet controller with quad fully integrated Gigabit Ethernet Media Access Control (MAC) and PHY.

In addition to managing MAC and PHY Ethernet layer functions, the controller manages PCI Express packet traffic across its transaction, link, and physical/logical layers.



Silicom's Quad Port Copper Gigabit Ethernet ExpressModule Bypass server adapters are the ideal solution for implementing multiple network segments, mission-critical high-powered networking applications and environments within high performance servers.

Key Features

Bypass:

- Bypass / Disconnect Ethernet ports on Power Fail, System Hangs or Software Application Hangs
- Software programmable Bypass, Disconnect or Normal Mode
- On Board Watch Dog Timer (WDT) Controller
- Software programmable time out interval
- Software Programmable WDT Enable / Disable counter
- Software programmable Bypass Capability Enable / Disable
- Software Programmable Disconnect Capability Enable / Disable
- Software Programmable mode (Bypass, Normal or Disconnect mode) at Power up
- Software Programmable mode (Bypass, Normal mode) at Power off
- Independent Bypass operation in every two ports

Copper Gigabit Ethernet 1000Base-T:

- Independently copper Gigabit Ethernet channels support four Gigabit Ethernet (1000Base-T), Fast Ethernet (100Base-Tx) and Ethernet (10Base-T).
- Triple speed 1000Mbps (1000Base-T), 100 Mbps (100Base-Tx) and 10 Mbps (10Base-T) operation
- Nway auto negotiation automatic sensing and switching between 1Gbps full duplex and 100 / 10 Mbps operations Simplex or Full Duplex
- RJ-45 female connectors

Performance Features:

- 8 Transmit and Receive queues per port
- Up to 8 queues of Receive Side Scaling (RSS) minimize CPU utilization across multiple processor systems
- Support for 8 pools (single queue) of virtual machine Device Queues (VMDq) per port
- Support Direct Cache Access (DCA)
- Support Intel I/O Acceleration Technology v3.0.
- TSO interleaving for reduced latency
- Minimized device I/O interrupts using MSI and MSI-X
- UDP, TCP and IP checksum offload
- UDP and TCP transmit segmentation offload (TSO)

- SCTP receive and transmit checksum offload
- Packet interrupt coalescing timers (packet timers) and absolute- delay interrupt timers for both transmit and receive operation

Common Key features:

- PCI Express ExpressModule Electromechanical Specification Revision 1.0
- Support PCI Express Base Specification 2.0 (5 GTs)
- High performance, reliability, and low power use in Intel 82580 Quad integrated MAC + PHY and SERDES chip Controllers
- Ultra deep, packet buffer per channel lowers CPU utilization
- Hardware acceleration that can offload tasks from the host processor. The Controllers can offload TCP/UDP/IP checksum calculations and TCP segmentation
- Server class reliability, availability and performance features
- Link Aggregation and Load Balancing
- Switch dependent: 802.3ad (LACP), Generic Trunking (GEC / FEC)
- Switch and NIC Independent
- Failover
- Priority queuing – 802.1p layer 2 priority encoding
- Virtual LANs –802.1q VLAN tagging
- Jumbo Frame (9.5KB)
- 802.x flow control
- Multicast/ broadcast Packet replication
- Statistics for SNMP MIB II, Ethernet like MIB, and Ethernet MIB (802.3z, Clause 30)
- Supports Vital Product Data (VPD)
- LEDs indicators for link/Activity/Bypass Mode status
- Hot Plug not supported. Can be supported by assembly change

Technical Specifications

Bypass Specifications	
WDT Interval (Software Programmable):	3,276,800 mSec (3,276.8 Sec): Maximum 100 mSec (0.1 Sec) : Minimum WDT Interval = (2^wdt_interval_parameter)*(0.1) sec. wdt_interval_parameter: { Valid Range: 0-15}
Copper Gigabit Ethernet Technical Specifications – (1000Base-T) Adapters	
IEEE Standard / Network	Gigabit Ethernet, 1000Base-T Fast Ethernet, 100Base-TX

topology:	Ethernet, 10Base-T
Full duplex / Simplex	Support both Simplex & Full duplex operation in all operating speeds
Auto negotiation	Auto-negotiation between Full duplex and simplex operations and between 10Mb/s 100Mb/s speeds and duplex 1000Mb/s
Data Transfer Rate	1000 Mbit/s, 100 Mbit/s and 10 Mbits/sec in simplex mode per port 2000Mbit/s 200 and 20 Mbit/s in full duplex mode per port
Cables and Operating distance	10Base-T Category 3, 4, or 5 maximum 50m * 100Base-Tx Category 5 maximum 50m * 1000Base-T Category 5E maximum 50m * *Theoretical Distance – Defined as half a distance as stated by the IEEE 802.3 standard
Operating Systems Support	
Operating system support:	Windows Linux FreeBSD VMware
General Technical Specifications	
Interface Standard:	PCI ExpressModule Specification revision 1.0 PCI-Express Base Specification Revision 2.0 (5 GTs)
Board Size:	168.2mm x 98mm (6.62"X3.858")
PCI Express Card Type:	X8
PCI Express Voltage:	+12V +- 8%
PCI Connector:	Gold Finger: X8
Controller:	Intel 82580
Holder:	Not included
I/O:	Quad RJ45 located on edge of the board
Weight:	140 gr (4.938 oz)
Operating Temperature:	0°C – 50°C (32°F – 122°F)

Storage:	-20°C–65°C (-4°F–149°F)
EMC Certifications:	<p>FCC Part 15, Subpart B Class B</p> <p>Conducted Emissions</p> <p>Radiated Emissions</p> <p>CE EN 55022: 1998 Class B Amendments A1: 2000; A2: 2003</p> <p>Conducted Emissions</p> <p>Radiated Emissions</p> <p>CE EN 55024: 1998 Amendments A1: 2000; A2: 2003</p> <p>Immunity for ITE Amendment A1: 2001</p> <p>CE EN 61000-3-2 2000, Class A</p> <p>Harmonic Current Emissions</p> <p>CE EN 61000 3-3 1995, Amendment A1: 2001</p> <p>Voltage Fluctuations and Flicker</p> <p>CE IEC 6100-4-2: 1995</p> <p>ESD Air Discharge 8kV. Contact Discharge 4kV.</p> <p>CE IEC 6100-4-3:1995</p> <p>Radiated Immunity (80-1000Mhz), 3V/m 80% A.M. by 1kHz</p> <p>CE IEC 6100-4-4:1995</p> <p>EFT/B: Immunity to electrical fast transients 1kV Power Leads, 0.5Kv Signals Leads</p> <p>CE IEC 6100-4-5:1995</p> <p>Immunity to conductive surges COM Mode; 2kV, Dif. Mode 1kV</p> <p>CE IEC 6100-4-6:1996</p> <p>Conducted immunity (0.15-80 MHz) 3VRMS 80% A.M By 1kHz</p> <p>CE IEC 6100-4-11:1994</p> <p>Voltage Dips and Short Interruptions</p> <p>V reduc >95%, 30% >95% Duration 0.5per, 25per, 250per</p>
MTBF:	<p>95 (Years)</p> <p>* According to Telcordia SR-332 Issue 2. Environmental condition – GB (Ground, Fixed, and Controlled). Ambient temperature 40°C</p>
LEDs	
LEDs:	<p>(2) LEDs per port</p> <p>Left LED: Link/Act :</p> <p>Turns on link (Green),</p> <p>Blinks on activity (Green)</p> <p>Right LED : Link Speed / Bypass / Disconnect :</p> <p>Turns on Yellow 1G Link.</p> <p>Turns on Green 100M Link</p> <p>Turn off on 10M link</p>

	Blink Yellow on Disconnect Blink Green on Bypass
LEDs location:	LEDs are located on the PCB, visible via holes in the metal bracket. Each Green Bypass/Disc and Bi-Color Act/Link LEDs are located above their own RJ45 connector port
Connectors:	(1) Shielded quad RJ-45

Functional Description

Silicom's Quad Port Bypass adapter supports Normal, Bypass and Disconnect modes. In Normal mode, the ports are independent interfaces (see Figure 1: Normal mode, one Bypass pair is illustrated)

Figure 1: Normal Mode Functional Block Diagram

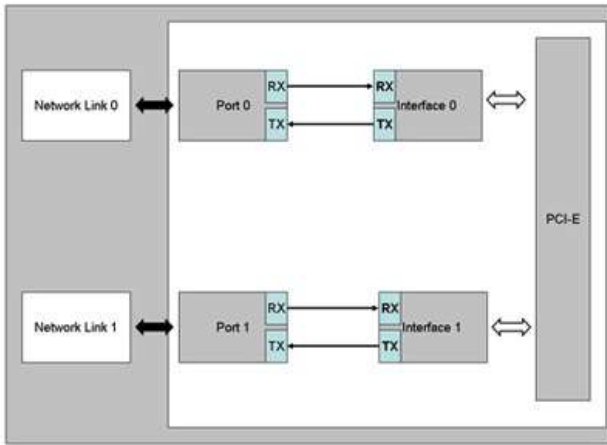

In Bypass mode, the connections of the Ethernet network ports are disconnected from the interfaces and switched over to the other port to create a crossed connection loop-back between the Ethernet ports. The connections of the interfaces are left unconnected. (See Figure 2: one Bypass pair illustrated)

Figure 2 : Bypass Mode Functional Block Diagram

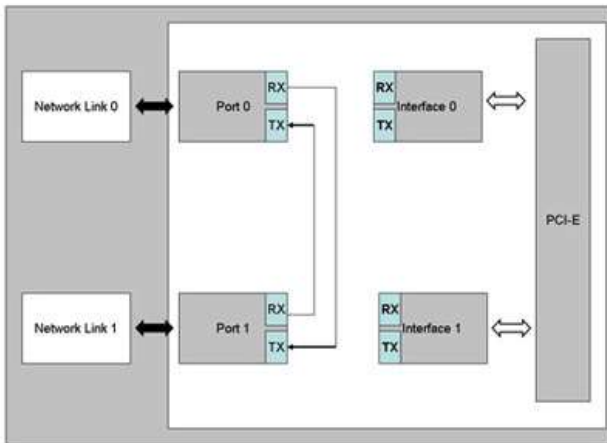

In Disconnect mode, the connections of the Ethernet network ports are disconnected from the interfaces. (See Figure 3: one Bypass pair illustrated)

Figure 3 : Disconnect Mode Functional Block Diagram

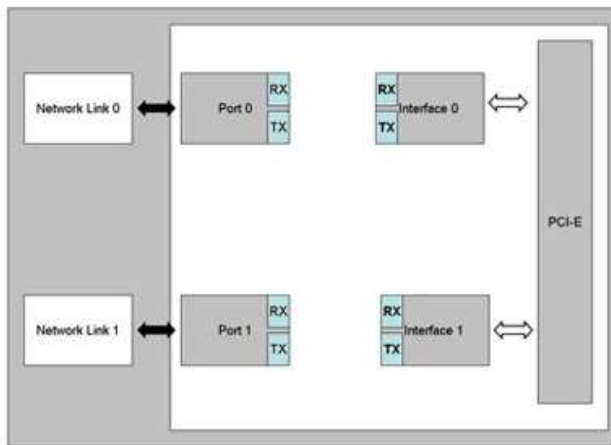

Silicom’s Quad Port Bypass adapter supports software programmable to select Normal, Bypass or Disconnect modes.

Silicom’s Quad Port Bypass adapter supports Disable Bypass, Disable Disconnected capabilities; hence, if those adapters receive Disable Bypass capability / Disable Disconnect commands, the adapter does not Bypass / does not Disconnect its Ethernet ports, The Disable Bypass Capabilities are reserved also after power off. This feature enables to emulate a standard NIC.

Silicom’s Quad Port Bypass adapter supports Disable supports setting the default mode at power up and power off. Those setting are reserved also after power off.

Order Information

P/N	Description	Notes
M1E2G4BPI80-SD-R	Quad Port Copper Gigabit Ethernet ExpressModule Bypass Server Adapter	X4, Based on Intel 82580EB, PCI-E ExpressModule, RoHS compliant

Note: Model P/N -SD

-SD: Side Driver

-R: RoHS Compliant / Lead free adapter

1V3